

Specifications

Model		U17-3	
Bucket capacity	m ³	0.04	
Std.bucket width: (with/without cutting edge)	mm	450 / 400	
Operating weight	kg	1,650	
Dimensions (in transport condition)	Overall length	3,545	
	Overall height	2,340	
	Overall width	990 / 1,240	
	Min. ground clearance	150	
Engine	Model	Kubota D902-K3A	
	Total displacement	L (cc)	0.898 (898)
	Output	kW (HP)/rpm	11.8 (16) / 2,300
Working range	Max. digging height	mm	3,540
	Max. dumping height	mm	2,440
	Max. digging depth	mm	2,310
	Max. vertical digging depth	mm	1,910
	Max. digging radius	mm	3,900
	Boom swing angle (Left / Right)	degree	65/58
	Min. turning radius (W/o swing / With swing)	mm	1,440 / 1,210
	Min. tail turning radius	mm	620
Hydraulic system	Pump capacity	L/min	17.3×2 / 10.4×1
	Auxiliary hydraulic flow	L/min	27.7
	Max. bucket breakout force	kN (kgf)	15.2 (1,550)
Track type		Steel	
Shoe width		mm	230
		mm	1,585
Travel section	Tumbler distance	mm	1,230
	Track gauge	mm	760 / 1,010
	Travel speed (Low / High)	km/h	2.1 / 4.1
	Gradeability	degree	30°
		rpm	9.1
Blade	Width	mm	990 / 1,240
	Height	mm	265
	mm	280 / 190	
Hydraulic pump type		Variable pump x 2 + gear pump x 1	
Swivel motor type		Orbit motor	
Travel motor type		Piston motor: 2F	
Fuel tank capacity	L	19	
Hydraulic oil (reservoir/system)	L	13 / 21	

*The company reserve the right to change specifications without notice.

Working Range

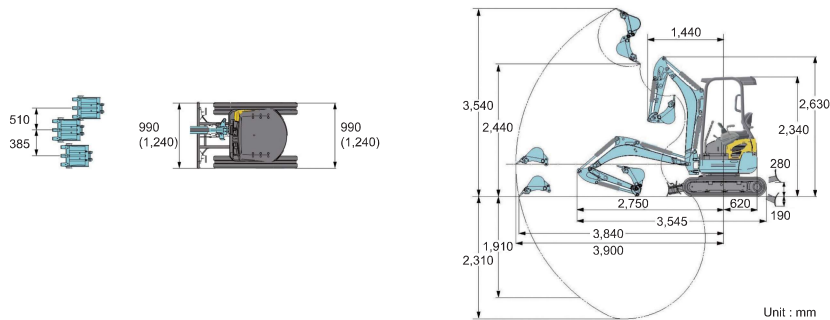

Unit : mm



陸機械私人有限公司
LAND EQUIPMENT PTE LTD

32 JOO KOON ROAD SINGAPORE 628985
TEL: (65) 6862-5223 FAX: (65) 6861-5223
E-Mail: sales@land-equipment.com.sg
Website: <http://www.land-equipment.com.sg>

AKK1638

U17-3

For Earth, For Life
Kubota

Kubota Mini Excavator

